

Machining recommendations for Strenx[®]

Table of contents

Introduction	4
Tool suppliers we recommend and have collaborated with	5
Drilling recommendations	6
Countersinking and counterboring recommendations	10
Tapping recommendations	12
Milling recommendations	14
Turning recommendations	20
Troubleshooting for drilling and milling	22
Tool recommendations	24

The contents of this brochure represent general suggestions. SSAB accepts no responsibility for their suitability in individual cases. The user is therefore responsible to make the necessary adaptations to the conditions in each individual case.



Introduction

Strenx® performance steel can be machined with high speed steel (HSS) or cemented carbide (CC) tools. This brochure includes our suggestions for cutting data (feeds and speeds) and the selection of tools. Other factors that should be taken into account in machining operations are also discussed. The proposals have been drawn up following our own tests on tools of various makes and in consultation with leading tool manufacturers.

The recommended cutting data and selection of tools also apply to our Strenx® MC, Plus and MC Plus of equal strength grade. For Strenx® 600 MC, Strenx® 650 MC, Strenx® 100, Strenx® 100 XF and Strenx® 110 XF use the same data as for Strenx® 700.

Typical properties for Strenx®

	Hardness in Brinell (HBW)	Hardness in Rockwell (HRC)	Tensile strength, Rm (N/mm ²)
Strenx® 700	~260	~24	~860
Strenx® 900	~300	~29	~935
Strenx® 960	~320	~32	~990
Strenx® 1100	~430	~43	~1340
Strenx® 1300	~500	~49	~1580

Tensile test R_m (N/mm²)

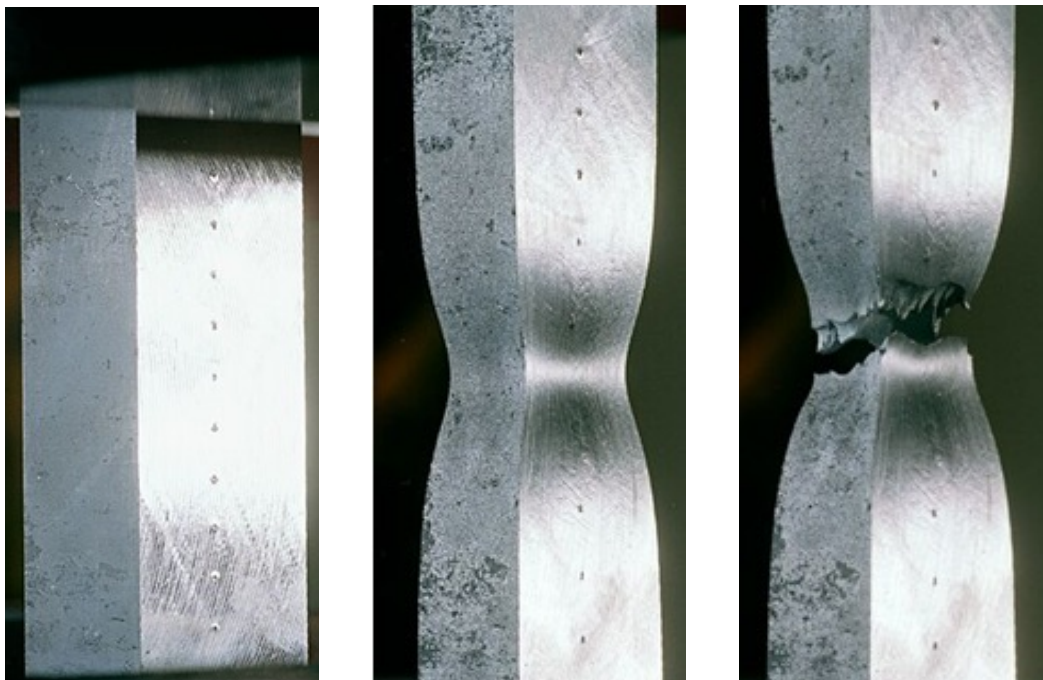

Tool suppliers we recommend and have collaborated with

All the recommendations in this brochure are based on results after practical testing of numerous tools in different situations. We collaborate with some of the worlds' leading fabricators of tools which we highly recommend using.

Fabricators	
Dorato Tools	www.d-tools.se
Emuge Franken	www.emuge-franken.de
Granlund Tools	www.granlund.com
Hoffmann Group	www.hoffmann-group.com
IZAR Cutting Tools	www.izartool.com
ISCAR	www.iscar.com
Komet Group	www.kometgroup.com
Manigley	www.manigley.ch
Mitsubishi	www.mitsubishicarbide.com
Sandvik Coromant	www.sandvik.coromant.com
SECO TOOLS	www.secotools.com
Witech	www.witec-tools.de
WNT	www.wnt.com



Drilling recommendations



HSS-drill

Use only HSS drills when you have unstable machine conditions. HSS drills are only suitable up to 500 Brinell. If the machine conditions are good you have several choices of solid cemented carbide drills with exchangeable heads or indexable insert drills.

Advice for reducing vibrations and increasing the lifetime of the drill

- ✓ Minimize the distance to the column and between the drill tip and the workpiece
- ✓ Don't use a longer drill than necessary
- ✓ Always use metal supports and clamp the workpiece securely
- ✓ Solid and firm table
- ✓ Always use coolant
- ✓ Coolant mix 8-10%
- ✓ Just before the drill breaks through, disengage the feed rate for about a second, play/springback can otherwise snap the drill tip, re-engage the feed rate when the play/springback has ceased

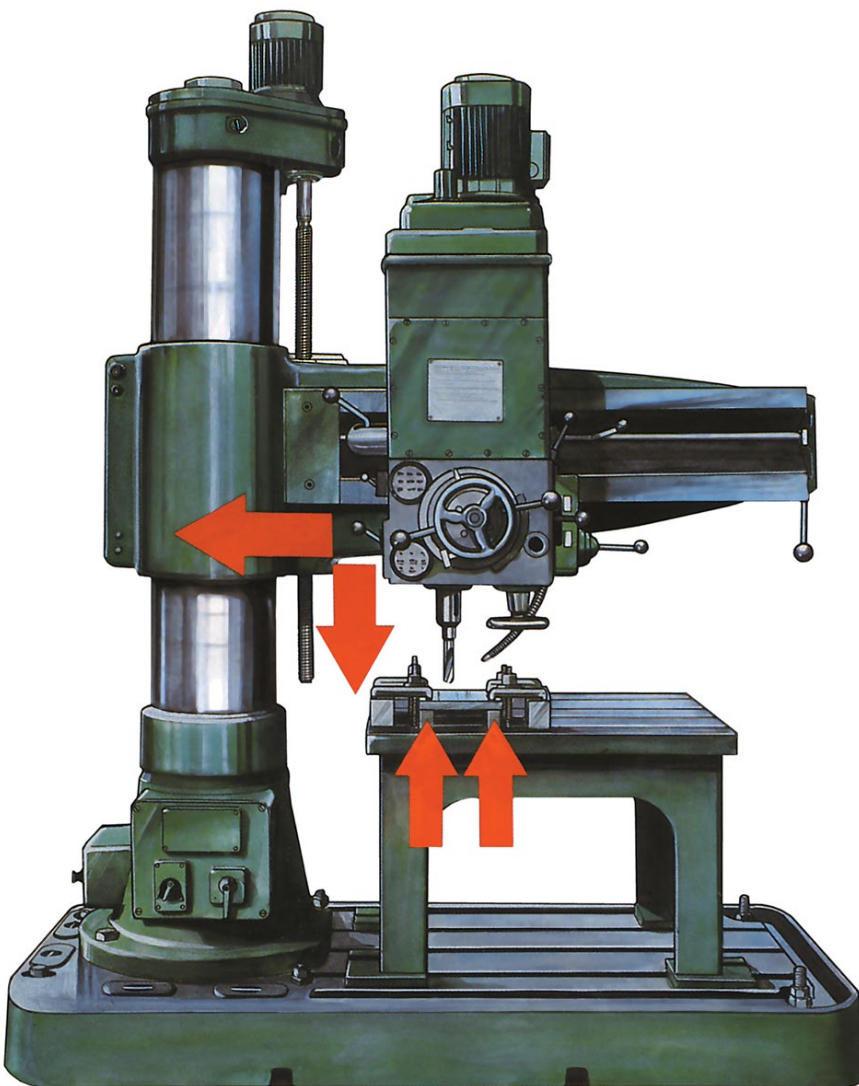

	Strenx® 700	Strenx® 900/960	Strenx® 1100	Strenx® 1300
Vc (m/min)	~ 18	~ 15	~ 7	~ 5
Drill Ø	Feed rate, fn (mm/rev) and speed (rpm)			
5	0.06/1150	0.06/950	0.05/445	0.04/280
10	0.12/570	0.11/475	0.10/220	0.08/140
15	0.17/380	0.16/320	0.15/150	0.12/95
20	0.24/290	0.23/240	0.20/110	0.16/70
25	0.30/230	0.29/190	0.25/90	0.20/55
30	0.36/190	0.35/160	0.30/75	0.24/45



HSS, HSS-E, HSS-Co
Individual holes can be drilled with an ordinary HSS drill. For rational production, either a microalloyed (HSS-E) drill or a cobalt-alloyed (HSS-Co) drill is recommended.



HSS-Co
Use an HSS-Co drill (8% Co) with a small helix angle and a robust core that can withstand high torques.

Formulas and definitions

$$Vc = \pi \times d \times n / 1000$$

$$\pi = 3,14$$

$$n = Vc \times 1000 / \pi \times d$$

Vc=cutting speed (m/min)

$$vf = n \times fn$$

n=speed (rpm)

fn=feed rate (mm/rev)

vf=feed rate (mm/min)

d=drill diameter

Advice for drilling in thin plate below 8 mm

Important to have good support under the plate to avoid deflection.

1. Indexable drill is recommended, because it begins cutting at the periphery, and does not build up the high pressure a solid carbide drill would do.
2. With a drill diameter over Ø 10 mm and a point angle of 118-140° it is very important to support the plate that is drilled. If the drill tip breaks through the bottom surface without a supporting plate to guide the tip, it may result in an oval and undersized hole (see picture).
3. Reduce feed rate and increase cutting speed Vc, especially when using an indexable drill.

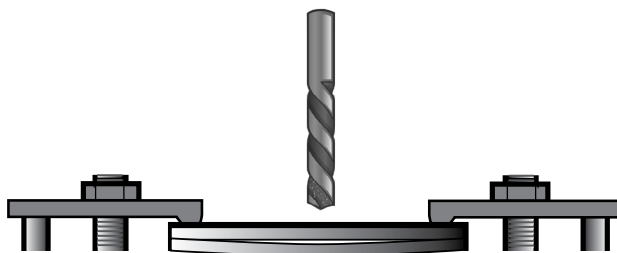
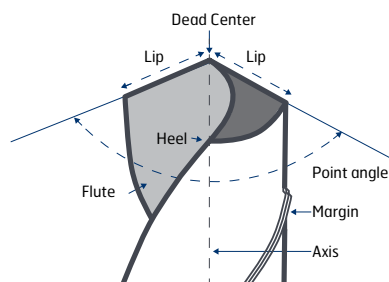

Solid cemented carbide drill

For stable machine conditions and with internal coolant.

	Strenx® 700	Strenx® 900/960	Strenx® 1100	Strenx® 1300
Vc (m/min)	70-100	60-90	40-60	35-50
fn (mm/rev)	min-max	min-max	min-max	min-max
Diameter	3.0-5.0	0.03-0.06	0.03-0.06	0.03-0.05
	5.01-10.0	0.06-0.12	0.06-0.12	0.05-0.11
	10.01-15.0	0.12-0.18	0.12-0.18	0.11-0.16
	15.01-20.0	0.18-0.25	0.18-0.24	0.16-0.22

- Drilling 7x Dc, reduce the feed rate ~20%.
- Drilling with external coolant, reduce the speed and feed rate ~ 20%.



Indexable insert drill

For stable machine conditions and with internal coolant.

Important: Use as short drill as possible. The recommendations are for 2XØ.

	Strenx® 700	Strenx® 900/960	Strenx® 1100	Strenx® 1300
Vc (m/min)	100-150	80-140	50-90	40-70
fn (mm/rev)	min-max	min-max	min-max	min-max
Diameter	12.0-20.0	0.04-0.10	0.04-0.10	0.04-0.08
	20.01-30.0	0.06-0.12	0.06-0.12	0.04-0.10
	30.01-44.0	0.06-0.14	0.06-0.14	0.06-0.12
	44.01-63.5	0.08-0.16	0.08-0.16	0.08-0.14

- The cutting data for indexable drill has been formulated in co-operation with Sandvik Coromant.



Drills with exchangeable drill heads

For stable machine conditions and with internal coolant.

	Strenx® 700	Strenx® 900/960	Strenx® 1100	Strenx® 1300
Vc (m/min)	70-100	60-90	40-60	35-50
fn (mm/rev)	min-max	min-max	min-max	min-max
Diameter	7.5-12.0	0.08-0.13	0.08-0.13	0.06-0.10
	12.01-20.0	0.13-0.22	0.13-0.22	0.10-0.14
	20.01-25.0	0.22-0.28	0.22-0.27	0.14-0.18
	25.01-33.0	0.28-0.37	0.27-0.36	0.18-0.24

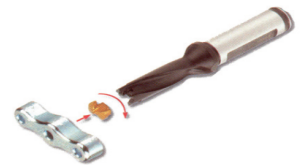



Countersinking and counterboring recommendations

Countersinking/boring is best performed using tools with replaceable inserts from the tool supplier Granlund. Always use a revolving pilot and use coolant. See table below for screw and article number for the tool. Reduce the cutting data with about 30% for countersinking.

	Strenx® 700	Strenx® 900/960	Strenx® 1100	Strenx® 1300
Vc (m/min)	70-100	40-80	20-50	15-45
fn (mm/rev)	0.10-0.20	0.10-0.20	0.10-0.20	0.10-0.20
Diameter	Speed (rpm)			
18.0-26.0	855-1770	490-1415	245-885	185-795
26.0-38.0	590-1225	335-980	170-610	125-550
38.0-47.0	475-840	270-670	135-420	100-380
47.0-60.0	370-680	210-540	105-340	80-305



WHV



KV9

Countersinking and counterboring table for screws

Size	Article number	Ø screw head
M8	0KV9-18.0	16
M10	0KV9- 20.5 / 1KV9- 20.0	20
M12	0KV9- 25.0 / 1KV9- 26.0	24
M14	1KV9- 30.0	27
M16	1KV9- 30.0 / 2KV9- 32.0	30
M20	2KV9- 38.0	36
M24	2KV9- 40.0	39
Size	Article number	Ø screw head
M10	0WHV- 18.0	16
M12	0WHV- 20.0 / 1WHV- 20.0	18
M14	0WHV- 23.0 / 1WHV- 23.0	21
M16	1WHV- 26.0	24
M20	1WHV- 32.0	30
M24	1WHV- 38.0 / 2WHV- 38.0	36
M30	2WHV-47.0	45



Tapping recommendations



With correct tools and tool holders we recommend tapping up to 500 Brinell with four-flute taps that can withstand the very high torque occurring during tapping in hard materials. If diameter is not critical, the drilled hole can be 3% larger than standard (see table below). This will increase the lifetime of the tap.

	Strenx® 700	Strenx® 900/960	Strenx® 1100	Strenx® 1300
Vc (m/min)	10-12	7-10	3-5	2.5-3.5
Size	Speed (rpm)			
M5	635-765	445-635	-*	-*
M6	530-640	370-530	210-320	-*
M8	400-480	280-400	160-240	100-140
M10	320-380	225-320	125-190	80-110
M12	265-320	185-265	105-160	65-95
M14	225-275	160-225	90-135	57-80
M16	200-240	140-200	80-120	50-70
M20	160-190	110-160	65-95	40-55
M24	130-160	90-135	50-80	30-45
M27	120-140	80-120	45-70	30-40
M30	105-125	75-105	40-65	25-35

* Tapping is not suitable. We recommend thread milling.

Emuge Franken is one tool supplier that have the type of tool holders we recommend for tapping, see picture to the right.

Size	Pitch	Drill Ø min-max
M4	0.7	3.3-3.4
M5	0.8	4.2-4.3
M6	1	5.0-5.1
M8	1.25	6.8-6.9
M10	1.5	8.5-8.7
M12	1.75	10.25-10.5
M14	2	12-12.3
M16	2	14-14.3
M20	2.5	17.5-18
M24	3	21-21.5
M27	3	24-24.5
M30	3.5	26.5-27.0

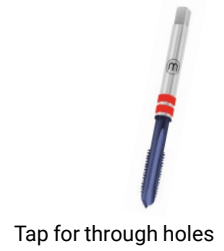

Tap for through holes



Tap for blind holes



Floating chuck for drilling/CNC machines.



Soft synchro chuck for CNC machine.

Thread milling recommendations

A CNC machine is necessary for thread milling. The tool supplier can provide programming support for the CNC machines.

	Strenx® 700	Strenx® 900/960	Strenx® 1100	Strenx® 1300
Vc (m/min)	100-130	80-110	50-70	40-60
fz (mm/tooth)	0.03-0.06	0.03-0.06	0.02-0.05	0.02-0.05



Tapping and thread milling advice

- Taps for blind holes have shorter lifetime due to the smaller core diameter.
- Before tapping, make sure that the predrilled hole is in good condition (don't use worn out drills).
- Always use coated taps.
- Make the thread milling in 2 passes.
- Make sure that the coolant mix is between 8-10%.
- We recommend climb milling.



Milling recommendations



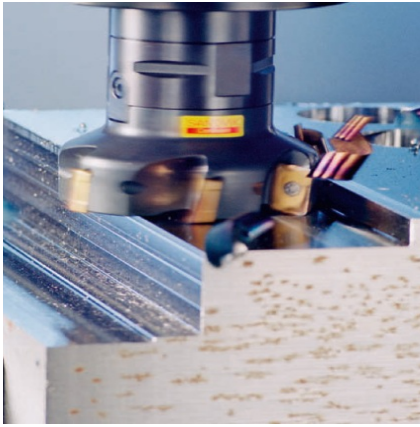

Milling advice

- Position the cutter off-center (to the left) to achieve a thicker chip at the entry and to avoid thick chip at the exit.
- Avoid cutting through the center line of the cutter, as this could generate vibration.
- Always use down milling (climb milling).
- The recommendation is that the width of the cut (a_e) is 25 or 75-80% of the diameter.
- Use rolling into cut method.
- Dry milling is recommended if insert is used.
- If the machine power is low use a coarse pitch cutter.
- Always use wise or good clamping equipment.
- The depth of cut with milling gas-cut edges should be at least 2 mm, to avoid the hard surface layer of the cut edge.

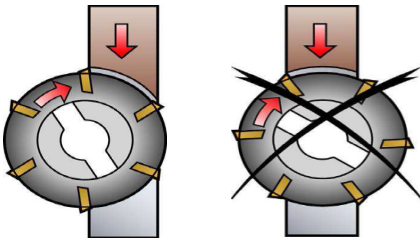

Formulas and definitions

$$n = \frac{V_c \times 1000}{\pi \times d}$$

$$\pi = 3,14$$

$$V_c = \pi \times d \times n / 1000$$

V_c =cutting speed (m/min)

$$v_f = f_z \times n \times z_n$$

n =speed (rpm)

$$f_z = \frac{v_f}{n \times z_n}$$

f_z = feed rate per tooth (mm/tooth)

v_f =feed rate (mm/min)

z_n =number of cutting edges

d =tool diameter

a_p =cutting depth (mm)

If you enter the workpiece with the rolling into cut method the chip thickness on the exit is always zero, and it will help to give a longer tool life.



Rolling into cut method



Straight into the workpiece

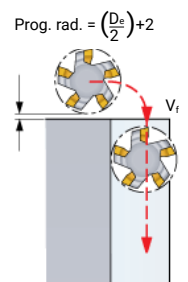

Inserts grades for milling

P	ISO	ANSI	
P	01	C8	↑
	10	C7	
	20	C6	
	30	C6	
	40	C5	
	50	C5	↓
M	10		↑
	20		
	30		
	40		↓
K	01	C4	↑
	10	C3	
	20	C2	
	30	C1	
	40		↓
H	01	C4	↑
	10	C3	
	20	C2	
	30	C1	↓

Workpiece material

P	ISO P= Steel
M	ISO M = Stainless steel
K	ISO K = Cast iron
H	ISO H = Hardened steel

↑ = Wear resistance

↓ = Toughness

* Example insert grade 1030.

The last 2 numbers in the insert grade indicate the position of the insert in this scale, if the insert has wear or toughness resistance.

Insert geometry

The macro geometry affects many parameters in the cutting process. An insert with strong cutting edge can work at higher loads, but it will also generate higher cutting forces, consume more power and generate more heat.



Parameter	L	M	H	
Edge strength				
Cutting forces				
Power consumption		← Low	Medium	High →
Max chip thickness				
Heat generated				

- Use inserts grade P30-50 with light cutting geometry and a coarse-pitch cutter if the machine power is low and with unstable machine conditions.



Face milling recommendation with a 45° setting angle

Indexable insert drill

In very stable machine conditions and with rigid set-up the insert grade P10 would be more suitable in all milling operations with inserts. Then the cutting speed can be increased by approximately 80-100%.

Recommendation for average machine conditions.

	Strenx® 700	Strenx® 900/960	Strenx® 1100	Strenx® 1300
Vc (m/min)	200-250	180-220	110-150	100-140
Feed rate (fz)	min-max	min-max	min-max	min-max
Insert grade P30	0.15-0.35	0.15-0.35	0.15-0.35	0.15-0.35



Face milling recommendation with round inserts

Round inserts have strong cutting edges and are good to use when the surface has holes and cavities etc.

Recommendation for average machine conditions.

	Strenx® 700	Strenx® 900/960	Strenx® 1100	Strenx® 1300
Vc (m/min)	200-250	180-220	110-150	100-140
Feed rate (fz)	min-max	min-max	min-max	min-max
Insert grade P30	0.10-0.25	0.10-0.25	0.10-0.25	0.10-0.25



Shoulder milling recommendation with a 90° setting angle

Recommendation for average machine conditions.

	Strenx® 700	Strenx® 900/960	Strenx® 1100	Strenx® 1300
Vc (m/min)	200-250	180-220	110-150	90-130
Feed rate (fz)	min-max	min-max	min-max	min-max
Insert grade P30	0.12-0.25	0.12-0.25	0.12-0.25	0.12-0.25



Hole making with high feed milling (circular ramping)

Circular ramping (also called helical interpolation, spiral interpolation) can be an alternative to drilling.

It is a simultaneous movement in a circular path (X and Y) together with an axial feed (Z) with a defined pitch (P). To manage circular ramping a CNC machine is necessary.

Advice

- Use compressed air to remove metal chips.
- Always down-milling/climb milling.
- P = pitch mm/rev.
- Max pitch with insert size 09 is 1,2 mm.
- Max pitch with insert size 14 is 2,0 mm.

Circular ramping

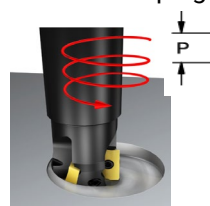

Recommendation for average machine conditions.

	Strenx® 700	Strenx® 900/960	Strenx® 1100	Strenx® 1300
Vc (m/min)	200-250	180-220	110-150	100-140
Feed rate (fz)	min-max	min-max	min-max	min-max
Insert grade P30	0.15-0.35	0.15-0.35	0.15-0.35	0.15-0.35

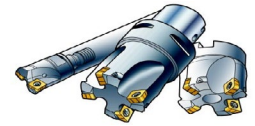

Coromill 210

• The fz and pitch/rev are recommendations for Coromill 210 from Sandvik Coromant.

End milling recommendation for solid cemented carbide tool

Slot milling recommendation.

	Strenx® 700	Strenx® 900/960	Strenx® 1100	Strenx® 1300
Vc (m/min)	95-120	85-110	70-95	45-70
Feed rate (fz)	min-max	min-max	min-max	min-max
Diameter	3.0-6.0	0.01-0.035	0.01-0.03	0.01-0.025
	8.0-12.0	0.04-0.07	0.03-0.06	0.03-0.05
	14.0-20.0	0.07-0.10	0.06-0.08	0.05-0.07

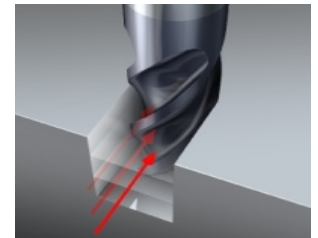

Slot milling advice

Ap (depth of cut)
max 0.5x D

Shoulder milling recommendation.

	Strenx® 700	Strenx® 900/960	Strenx® 1100	Strenx® 1300
Vc (m/min)	210-240	180-210	160-190	120-150
Feed rate (fz)	min-max	min-max	min-max	min-max
Diameter	3.0-6.0	0.02-0.05	0.02-0.04	0.015-0.035
	8.0-12.0	0.07-0.10	0.06-0.09	0.05-0.07
	14.0-20.0	0.10-0.14	0.10-0.13	0.08-0.10

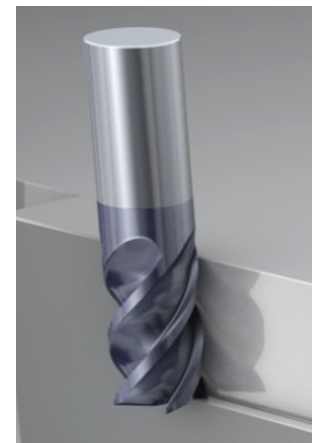

Shoulder milling advice

ap (use the whole
cutting length)

ae (radial depth of cut) max
0.1 x D

• If possible, use only compressed air to remove the chip and use weldon chuck for tool over Ø 10 mm.

Turning recommendations



The cutting data recommendations below are applicable for tough cemented carbide grades. These grades are necessary for operations in which impact may occur, such as when turning plate with gas-cut edges.

Inserts grade	P25 / C6	P35 / C6-C7	K20 / C2
Feed rate f_n (mm/rev)	0.1 - 0.4 - 0.8	0.1 - 0.4 - 0.8	0.1 - 0.3
Cutting speed V_c (m/min)			
Strenx® 700	285-195-145	230-150-100	-
Strenx® 900/960	130-90-70	105-65-45	-
Strenx® 1100	130-90-70	105-65-45	-
Strenx® 1300	-	-	100-80

- At higher feed rate, reduce the cutting speed.

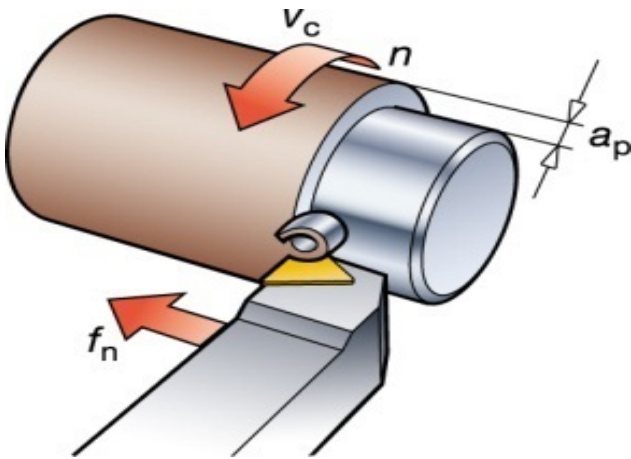

Formulas and definitions

$$V_c = \pi \times d \times n / 1000$$

$$\pi = 3,14$$

$$n = V_c \times 1000 / \pi \times d$$

V_c =cutting speed (m/min)

$$v_f = n \times f_n$$

n =speed (rpm)

f_n =feed rate (mm/rev)

v_f =feed rate (mm/min)

d =workpiece \emptyset

a_p =cutting depth (mm)



Troubleshooting for drilling and milling

Drilling

Short lifetime of cemented carbide tool		●	●	●	●	●				
Short lifetime of HSS tool			●	●		●		●	●	
Vibrations	●			●		●				●
Wear on the cutting edge/margin				●	●			●		
Wear on the chisel edge/drill center				●			●			●
Asymmetrical holes			●	●		●				●
Small chipping on the cutting edges	●		●				●			
Chip build-up in the drill flutes		●		●			●			●
Chipping on the corner of the cutting edges		●		●	●	●				
Holes oversize/undersize				●		●				●

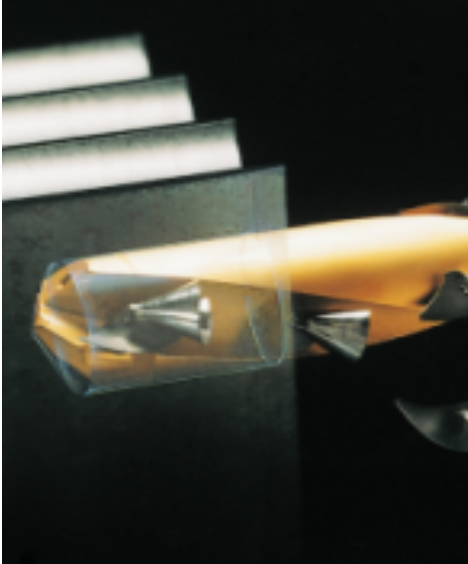

Choose a tougher cemented carbide grade.

Increase the coolant flow rate and clean the coolant holes of the drill.

Check that the right HSS or cemented carbide grade is used.

Check the guideline for the cutting data.

Check the toolholders and the total indicated run-out.

Improve the set-up of the workpiece / reduce long tool set-up.

Increase the cutting speed.

Reduce the cutting speed.

Increase the feed rate.

Reduce the feed rate.

Milling

Land wear		●			●			●		●
Cratering wear		●					●			●
Plastic deformation		●		●						●
Cutting edge build-up			●		●		●			
Chip jamming				●		●		●		
Small chipping on the cutting edges			●				●		●	
Short lifetime on the cutter/inserts		●			●			●		●
Vibrations	●	●			●	●	●	●		
Not enough horsepower/torque		●				●	●	●		



Position the cutter off-center, see page 15.

Reduce the cutting speed.

Increase the cutting speed.

Reduce the feed rate.

Increase the feed rate.

Use a coarse-pitch cutter.

Use smaller cutter and inserts with positive light cutting geometry, see page 16.

Reduce the cutting depth.

Check the set-up of the cutter.

Use a tougher inserts grade.

Use a more wear resistant inserts grade.

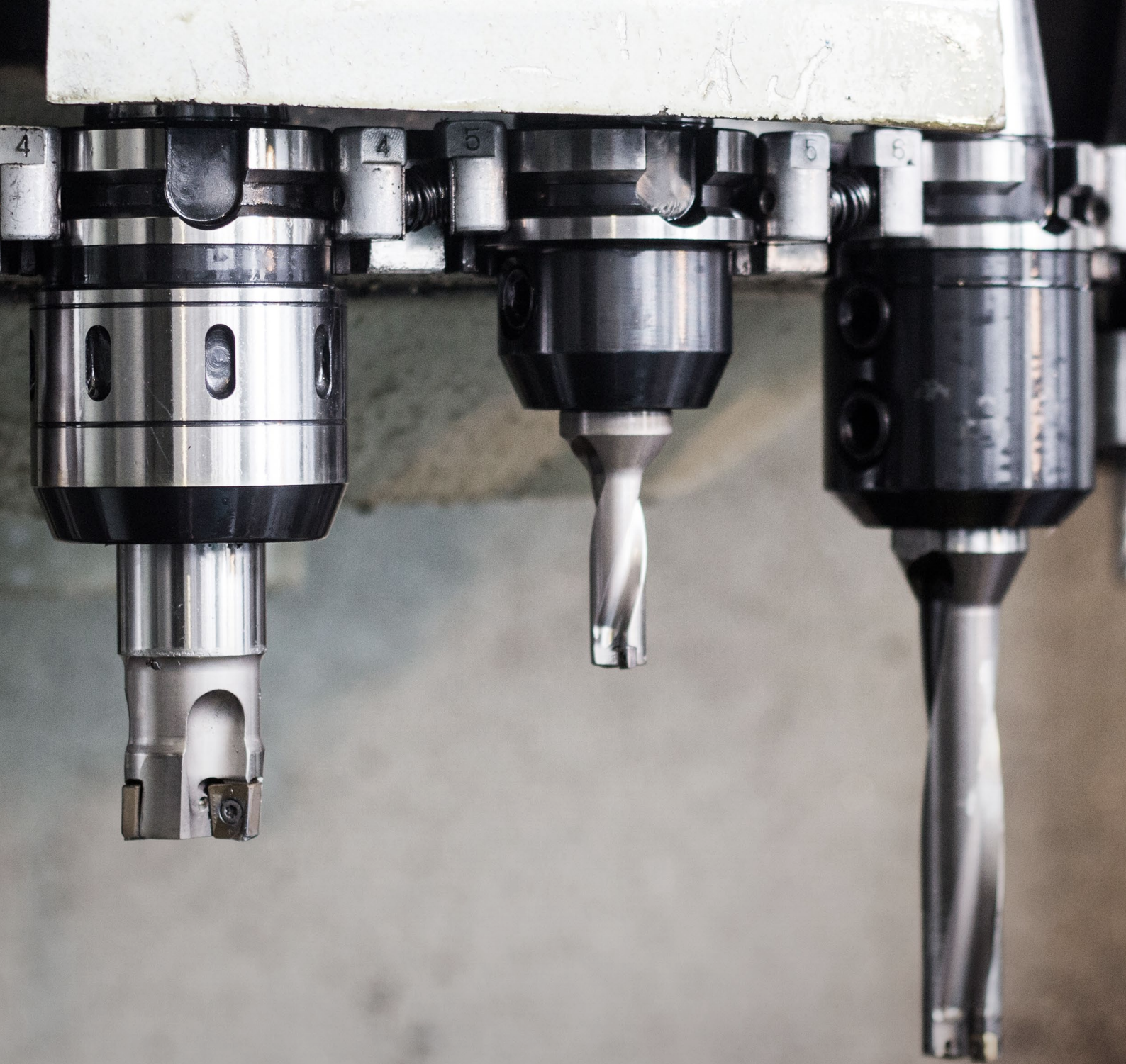

Tool recommendations

Drilling in Strenx®

High speed steel drill alloyed with 8% cobalt (HSS-Co 8%)

Supplier: Alpen-MayKestag, Austria. www.alpenmaykestag.com

Tool name	Article nr	Diameter range
HSS -E Co 8 Taper Shank Drills, WN 103	832xxxxx	8.0-40.0



High speed steel drill alloyed with 8% cobalt (HSS-Co 8%)

Supplier: Witec, Germany. www.witec-tools.de

Tool name	Article nr	Diameter range
TYPE WITEC MN	2-135 15 VAP	10.0-40.0



High speed steel drill alloyed with 8% cobalt (HSS-Co 8%)

Supplier: Somta, South Africa. www.somta.co.za

Tool name	Article nr	Diameter range
MTS Armour Piercing drill	261xxxx	10.0-50.0



High speed steel drill alloyed with cobalt

Supplier: Izar, Spain. www.izartool.com

Tool name	Article nr	Diameter range
Ref 1054	32xxx	2.0-12.0



High speed steel drill alloyed with cobalt

(DRILL BIT COBALT "S"+X-ALCR TAPER STUB). Supplier: Izar, Spain. www.izartool.com

Tool name	Article nr	Diameter range
Ref 1054	xxxxxx	14,0-30,0



High speed steel drill alloyed with 8% cobalt

(HSCo - 8%)

Supplier: Presto tools, England. www.presto-tools.co.uk

Tool name	Article nr	Diameter range
Armour Piercing drill (APX)	11211 xx.xx	5.0-32.0



Solid cemented carbide drill

Supplier: Emuge Franken, Germany. www.emuge.de/english

Tool name	Article nr	Diameter range
EF-Drill-STEEL	TA203344.xxxx	2.8-16.0



Solid cemented carbide drill

Supplier: Sandvik Coromant AB, Sweden. www.sandvik.coromant.com

Tool name	Article nr	Diameter range
Cordrill R840 Delta C	R840-xxxx-30-A1A	3.0-20.0



Solid cemented carbide drill

Supplier: Granlund Tool AB, Sweden. www.granlund.com



Tool name	Article nr	Diameter range
THUNDER / T80	T80-xx.x	10.0-30.0

Solid cemented carbide drill

Supplier: Mitsubishi, Japan. www.mitsubishicarbide.com



Tool name	Article nr	Diameter range
MPS1 (DP 1021)	MPS1-xxxxS	3.0-20.0

Solid cemented carbide drill

For hardness grade 450 Brinell and below, otherwise M-geometri.

Supplier: Seco, Sweden. www.secotools.com



Tool name	Article nr	Diameter range
Seco Feedmax	* SD203A-12,0-36-12R1	2.0-20.0

Solid cemented carbide drill

Supplier: WNT, Germany. www.wnt.com



Tool name	Article nr	Diameter range
WTX-UNI	11780	3.0-25.0

Solid cemented carbide drill

Supplier: Hoffmann-Group, Germany. www.hoffmann-group.com



Tool name	Article nr	Diameter range
Garant 122500	122500	1,0-20,0

Drill with exchangeable drill heads

Drillheads grade: IDI SG IC908. Supplier: Iscar, Israel. www.iscar.com



Tool name	Article nr	Diameter range
Chamdrill	DCM xxx-xxx-xxA-3D	7.5-25.9

Drill with exchangeable drill heads

Drillheads grade: ICP IC 908. Supplier: Iscar, Israel. www.iscar.com

Tool name	Article nr	Diameter range
SumoCham	DCN xxx-xxx-xxA-3D	6.0-32.0



Drill with exchangeable drill heads

Drillheads grade: P-geometry (HB 7530).

Supplier: Hoffmann-Group, Germany. www.hoffmann-group.com

Tool name	Article nr	Diameter range
HiPer-Drill	DCN xxx-xxx-xxA-3D	13,0-32,75



Drill with exchangeable drill heads

Drillheads grade: P-geometry (PM 4234).

Supplier: Sandvik Coromant AB, Sweden. www.sandvik.coromant.com

Tool name	Article nr	Diameter range
CoroDrill 870	870-xxxx-xxxx	10.0-33.0



Indexable insert drill

Insert grade: Center insert LM 1044. Peripheral insert LM 4044

Supplier: Sandvik Coromant, Sweden. www.sandvik.coromant.com

Tool name	Article nr	Diameter range
CoroDrill 880	880-Dxxxxxxx-xx	12.0-63.0



Indexable insert drill

Insert grade: Center insert LM 1044. Peripheral insert LM 4044

Supplier: Seco, Sweden. www.secotools.com

Tool name	Article nr	Diameter range
Perfomax	SD503-xx.x-xxR7	15.0-59.0



Counterboring in Strenx®

Use counterbore with indexable inserts and the inserts grade shall always end with H

Supplier: Granlund Tool, Sweden. www.granlund.com

Tool name	Article nr	Diameter range
WHV counterbore	XWHV-xx.x	18.0-75.0



Countersinking in Strenx®

Use countersink with indexable inserts and the inserts grade should always end with H.
Supplier: Granlund Tool, Sweden. www.granlund.com



Tool name	Article nr	Diameter range
KV countersink	xKV9-xx.x	20.5-60.0

Tapping in Strenx®

Tap for through holes. HSSE-PM tap with TiCN coating
Supplier: Manigley, Switzerland. www.manigley.ch



Tool name	Article nr	Diameter range
105/4 DUO	433xx	M3-M30

Tap for blind holes

HSSE-PM tap with TiCN coating
Supplier: Manigley, Switzerland. www.manigley.ch



Tool name	Article nr	Diameter range
131/3 DUO	433xx	M3-M36

Tap for through holes

HSS-E-PM with CoolTop coating
Supplier: Sandvik Coromant, Sweden. www.sandvik.coromant.com



Tool name	Article nr	Diameter range
CoroTap 200	E324 / E326	M3-M20

Tap for through holes

HSSE-PM with TiAlN coating
Supplier: Hoffmann-Group, Germany. www.hoffmann-group.com



Tool name	Article nr	Diameter range
Garant 132065	132065-Mxx	M3-M16

Tap for through holes

HSSE-PM with TiCN coating
Supplier: BASS, Germany. www.bass-tools.com



Tool name	Article nr	Diameter range
VARIANT 1/2 TIH	1088XX	M2-M16

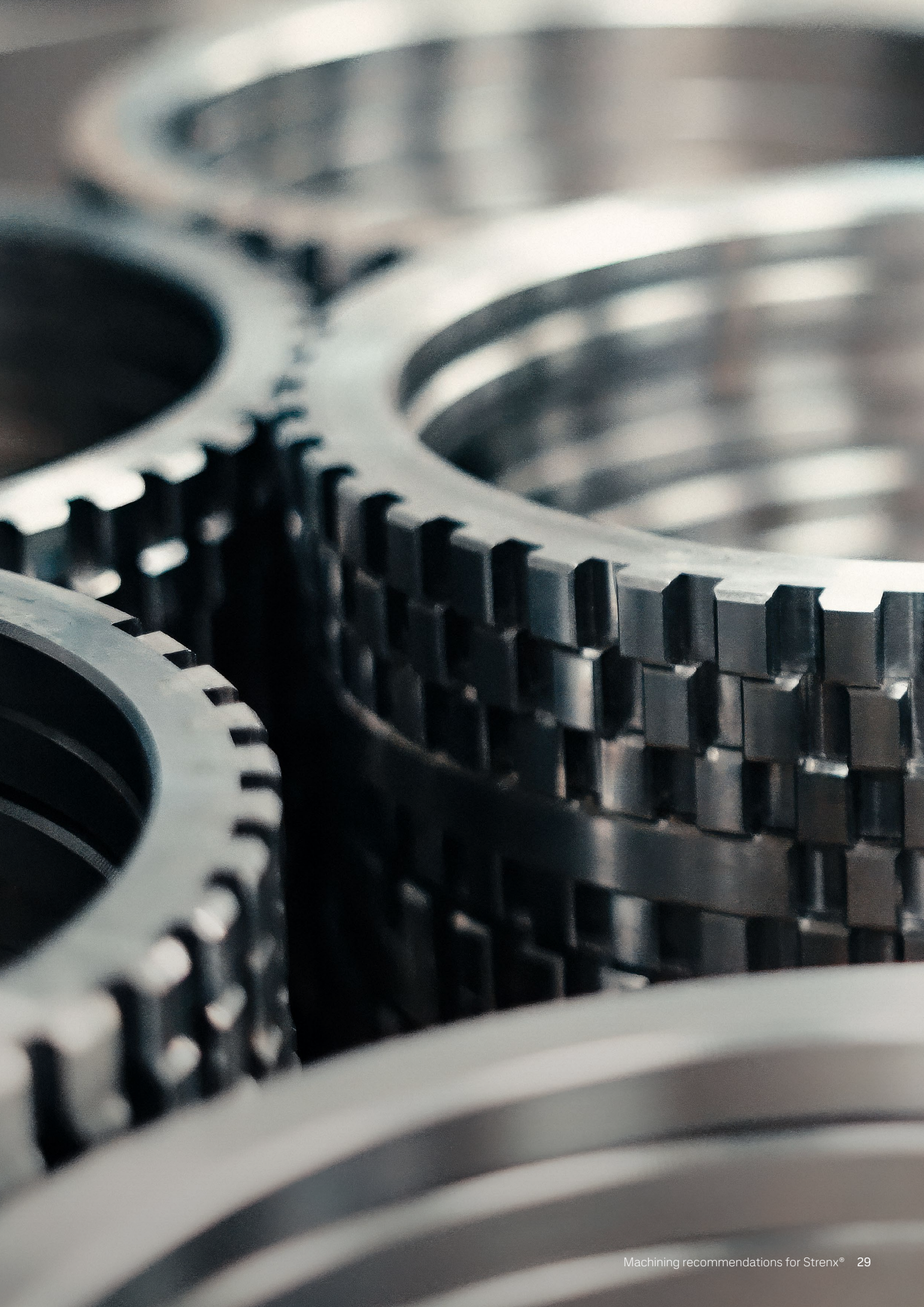

Thread milling in Strenx®

Solid carbide thread milling cutter with TiCN coating

Supplier: Emuge Franken, Germany. www.emuge.de/english



Tool name	Article nr	Diameter range
GF-VZ-VHM-R15-IKZ-HB	GFB35106.xxxx	M6-M24

Solid carbide thread milling cutter with TiCN coating

Supplier: Emuge Franken, German. www.emuge.de/english



Tool name	Article nr	Diameter range
GSF-VHM 2D IKZ-HB	GF333106.xxxx	M3-M16

End milling in Strenx®

Solid carbide end milling cutter with Siron-A coating

Supplier: Seco, Sweden. www.secotools.com



Tool name	Article nr	Diameter range
JS 554 Siron-A	JS554xxxx	3.0-25.0

Milling with insert in Strenx®

Face milling with Coromill 345

Supplier: Sandvik Coromant, Sweden. www.sandvik.coromant.com



Tool name	Article nr	Diameter range
Coromill 345	345-xxxxxx-13x	40-250

Face milling with Coromill 300

(Round inserts)

Supplier: Sandvik Coromant, Sweden. www.sandvik.coromant.com



Tool name	Article nr	Diameter range
Coromill 300	R300-xxxxxx-xxx	10-200

Shoulder/face milling with Coromill 490

Supplier: Sandvik Coromant, Sweden. www.sandvik.coromant.com



Tool name	Article nr	Diameter range
Coromill 490	490-xxxxx-xxx	20-250

Holemaking with high feed milling

Supplier: Sandvik Coromant, Sweden. www.sandvik.coromant.com

Tool name	Article nr	Diameter range
Coromill 210	R210-xxxxx-xxx	25-160



Insert grade in Strenx®

Use insert grade P1030 for average machine conditions. In very stable machines and with a rigid set-up the insert grade P1010 would be more suitable, especially over 500 Brinell.

Supplier: Sandvik Coromant, Sweden. www.sandvik.coromant.com

Tool name	Article nr/insert grade	Insert geometry
Coromill 210	R210-xxxxxx-Px 1010	M
	R210-xxxxxx-Px 1030	M
Coromill 300	R300-xxxxx-Px 1010	L-M-H
	R300-xxxxx-Px 1030	L-M-H
Coromill 345	345R-1305x-Px 1010	L-M-H
	345R-1305x-Px 1030	L-M-H
Coromill 490	490R-xxxxxx-Px 1010	L-M
	490R-xxxxxx-Px 1030	L-M-H

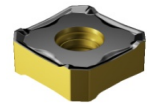

Portable magnetic drilling machines for Strenx®

Rotabroach Scorpion

Supplier: Rotabroach, United Kingdom. www.rotabroach.co.uk

Model nr.	Type of drill	Diameter range
Rotabroach Scorpion (Model CM 500)	TCT cutter for Strenx® (core drill)	12-100



SSAB is a Nordic and US-based steel company. SSAB offers value added products and services developed in close cooperation with its customers to create a stronger, lighter and more sustainable world. SSAB has employees in over 50 countries. SSAB has production facilities in Sweden, Finland and the US. SSAB is listed on Nasdaq Stockholm and has a secondary listing on Nasdaq Helsinki.

SSAB
P.O. Box 70
SE-101 21 Stockholm
SWEDEN

Visiting address:
Klarabergsviadukten 70

Telephone: +46 8 45 45 700
Email: contact@ssab.com

strenx.com

STRENX[®]
PERFORMANCE STEEL